

Applicator Guides produced by Rauschert Innovative Solutions for Microfilaments

Rauschert, the leading German manufacturer of yarn guides and other components introduces its new range of ceramic spin finish applicator guides, manufactured in Rapal 200 alumina and specially developed for critical high speed spinning applications.

The Applicators have been designed to optimise the configuration of the filaments in the lubrication zone, by using yarn-friendly contact geometry. This prevents “bunching” or “overcrowding” of the yarn filament bundle which can result in poor lubricant penetration, but retains sufficient dynamic control of the yarn to encourage even and continuous lubrication of each filament. The problem of dripping is also reduced because the yarn is presented to the lubricant in the most efficient way.

A denier range of between 20 and 400 can be accommodated and the design is suitable for micro-denier yarns and a range of filament counts.



Proposal for custom made applicator guide

Rapal 200 is a fine grain, high purity alumina ceramic, specially developed for textile applications. The applicators are available in a range of low friction surface finishes, specifically suited to high speed POY or FDY applications.

Applicators for higher denier and BCF yarns are available on request. In addition and to complement its extensive range of standard applicators, Rauschert also offers the flexibility of CNC manufacturing to fabricate applicators with additional features, for example, additional/fewer dimples (1-5 dimples), a wider yarn channel (0.5mm–4mm width) or bigger/smaller oil hole (0.5mm–2mm diameter). Applicators can therefore be made according to customers requirements.



Applicator guide 3.94768 / 1.0 PI

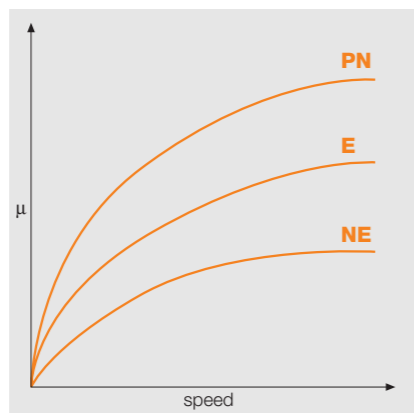

Friction diagramm

SEM NE quality

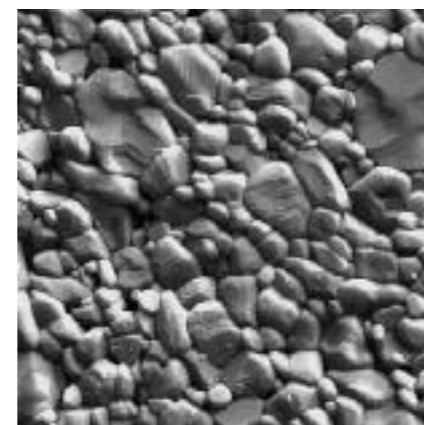

Our standard range of Applicator Guides

Type	3.94768 / 0.6		3.94768 / 1.0		3.94768 / 2.4	
	bright	semidull dull	bright	semidull dull	bright	semidull dull
HOY FDY 7000 m/min ↑ speed ↓ 2000 m/min POY	NE	NE	NE	NE	E	E
	NE	E	NE	E	E	E
	20 den	100 den	150 den	200 den	300 den	

**Microfilaments:
NE quality
Recommended
surface table**

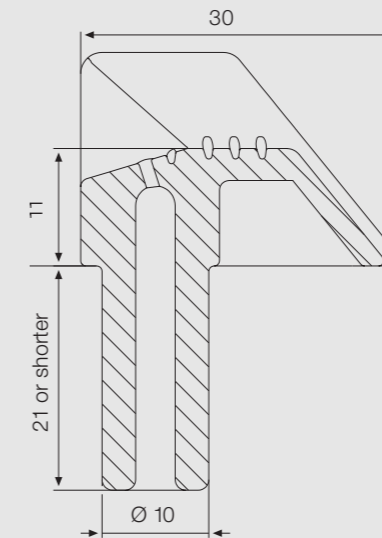

Applicator guide
3.94768 / 0.6*

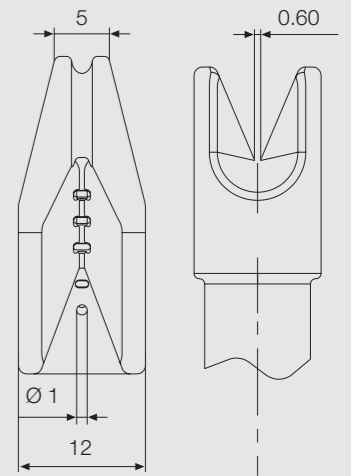

Applicator guide
3.94768 / 1.0*

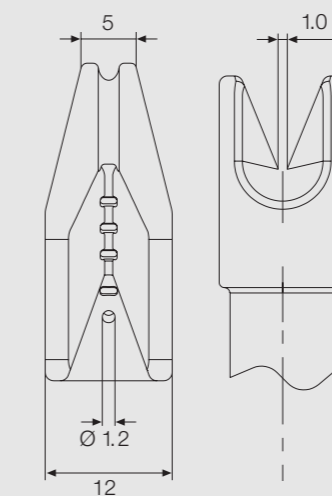

Applicator guide
3.94768 / 2.4*

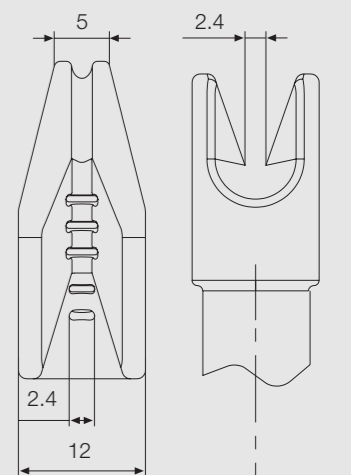

* details not shown



Technical Ceramics



Electroceramics



Ceramics for lightning



Ceramic components for textile machines



Ceramics for mechanical engineering



High temperature ceramics



Infrared heater plates



Ceramic honeycombs



Welding back-ups



Porous wicks



Ignition components



Ceramic coating



Ceramic sealing and regulation discs



Ceramic parts for pumps



Functional ceramics



Plastik Injection Moulding



2-component-plastic-parts



System components



Assemblies (ceramics/metal/plastic)

Rauschert Applicator Guides

Take advantage of the Rauschert experience!

The applicator guides belong to the textile ceramics business unit.

The production of ceramic yarn guides is a major business activity for Rauschert.

The Yarn Guides Product Division is very successful and has expanded greatly. Our goal is to be a competitive supplier in the marketplace. Management and employees are constantly striving to improve the quality of our products and efficiency of production.

The representatives for the Yarn Guides Product Division are based in Pressig/Germany and Shanghai/China. Pressig is located 120 km north of Nuremberg and can be reached via Autobahn A9 and A73.

Rauschert Textile Ceramics (Shanghai) Co., Ltd was founded in 2003 and is a supplier of textile ceramics for the Chinese market.

Send us your inquiries!

Rauschert
Heinersdorf-Pressig GmbH
Postfach 1162
D-96329 Pressig

Phone +49 9265-78-0
Fax +49 9265-78-10899
email info.prg@rauschert.de

Rauschert Technical Ceramics (Shanghai) Co., Ltd
Section A, Second Floor,
12# Standard Factory Building,
No. 55 Xi Ya Road, Waigaoqiao
Free Trade Zone, Shanghai
China 200131

Phone +86 215064-3668
Fax +86 215046-2220
email qiu@rauschert.com

With 100 years experience in supplying to industrial customers Rauschert can also be a reliable partner for you.

We have 1.500 employees in 13 countries and 16 manufacturing plants ensuring that Rauschert meets the international challenges of today.

Please request our literature or visit us on the internet!

www.rauschert.com



Applicator Guides produced by Rauschert Innovative Solutions for Microfilaments

04/09/0,5 The information in this leaflet are generally correct, however it is not possible to lay claim to liability or guarantee.

